

THIS DRAWING IS UNPUBLISHED. RELEASED FOR PUBLICATION
 © COPYRIGHT BY TYCO ELECTRONICS CORPORATION. ALL RIGHTS RESERVED.

LOC	DIST	REVISIONS			
P	LTR	DESCRIPTION	DATE	DWN	APVD
G	86	G	REDRAWN PER 0G3A-0400-04	02JUN04	JR MS

- 1 TONGUE MATERIAL THICKNESS .048±.003
- △ 2 BODY: COPPER PER ASTM B-152
TIN PER ASTM B-545
INSULATION: PVC, COLOR - YELLOW
METALLIC SLEEVE: COPPER PER ASTM B-152
METALLIC BAND: STEEL PER ASTM A109
- 3 FOR .436 MAX WIRE INSULATION DIA

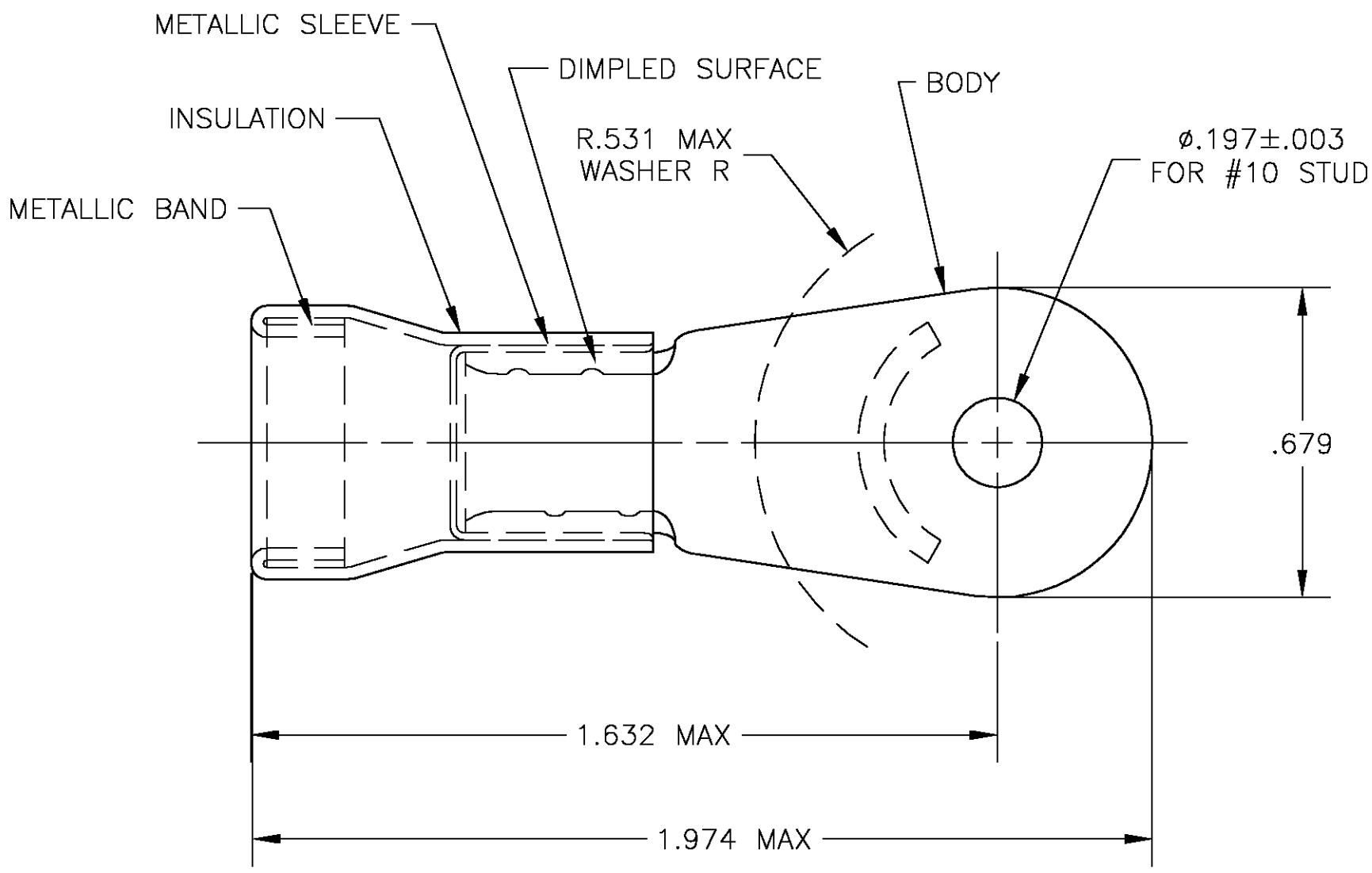

QTY	DESCRIPTION	PART NO
1	WIRE TERMINAL	322009

THIS DRAWING IS A CONTROLLED DOCUMENT.		DWN jr_ruth 02JUN04	Tyco Electronics Corporation Harrisburg, PA 17105	
DIMENSIONS: INCHES 		CHK MJ SPICER 02JUN04		
TOLERANCES UNLESS OTHERWISE SPECIFIED: 0 PLC ± - 1 PLC ± - 2 PLC ± - 3 PLC ± .008 4 PLC ± - ANGLES ± 5°		APVD MJ SPICER 02JUN04	NAME TERMINAL, AMPLI-BOND, RING TONGUE WIRE SIZE: 4	
MATERIAL - △ 2		FINISH - △ 2	PRODUCT SPEC -	APPLICATION SPEC -
		WEIGHT -	SIZE A3	CAGE CODE 00779
CUSTOMER DRAWING			DRAWING NO C-322009	RESTRICTED TO -
			SCALE 3:1	SHEET 1 OF 1
			REV G	